

TENSIONER MOUNTING POSITIONS

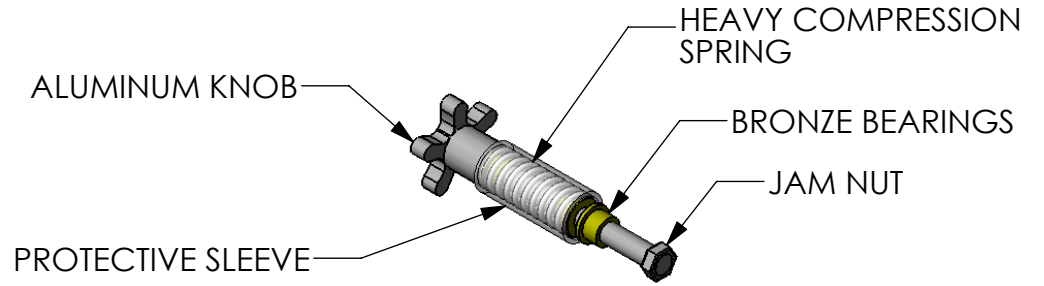

TENSIONER DETAIL

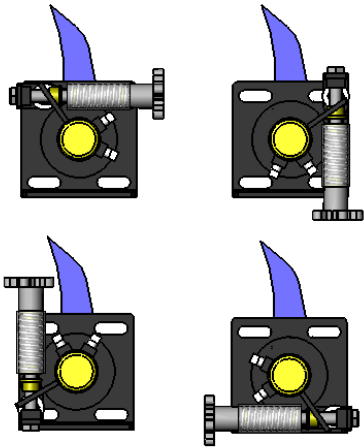
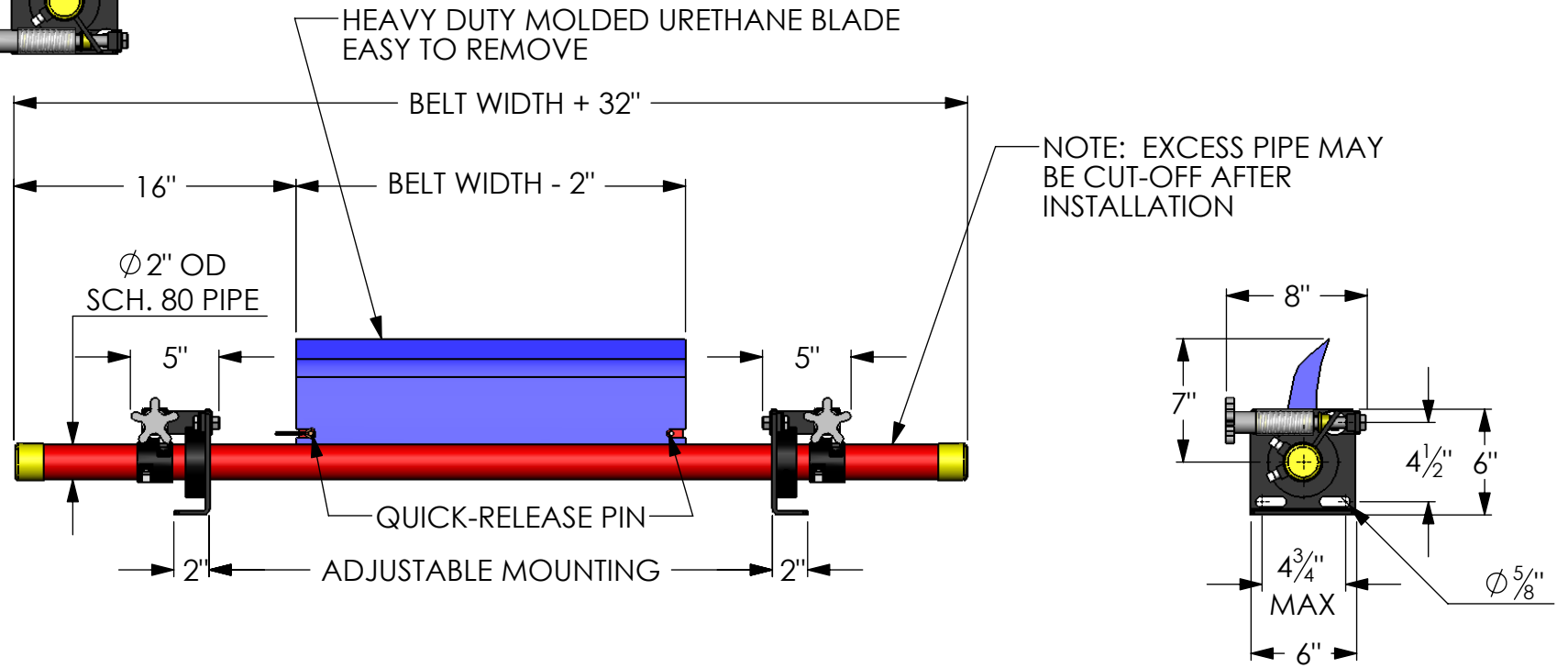

PROPRIETARY AND CONFIDENTIAL
 THE INFORMATION CONTAINED IN THIS DRAWING IS THE SOLE PROPERTY OF AMERICAN EAGLE MANUFACTURING. ANY REPRODUCTION IN PART OR AS A WHOLE WITHOUT THE WRITTEN PERMISSION OF AMERICAN EAGLE MANUFACTURING IS PROHIBITED.

		DIMENSIONS ARE IN INCHES		NAME	DATE
		TOLERANCES:		JWB	08/07/08
		FRACTIONAL ± 1/16"		CHECKED	
		ANGULAR: MACH ± 5° BEND ± 1°		ENG APPR.	
		TWO PLACE DECIMAL ± 0.05"		MFG APPR.	
		THREE PLACE DECIMAL ± 0.030"		Q.A.	
		MATERIAL		COMMENTS:	
NEXT ASSY	USED ON	FINISH			
APPLICATION		DO NOT SCALE DRAWING			

American Eagle Manufacturing		
TITLE: AG-DUTY PRIMARY BELT CLEANER - WITH DUAL TENSIONER 42" - 48"		
SIZE A	DWG. NO.	REV.
SCALE: 1:10	WEIGHT:	SHEET 1 OF 1