

TENSIONER MOUNTING POSITIONS

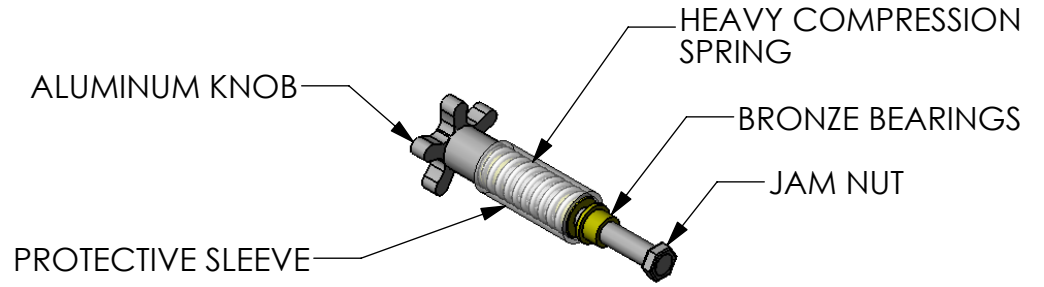

TENSIONER DETAIL

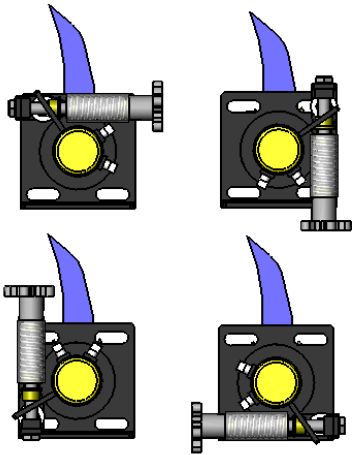
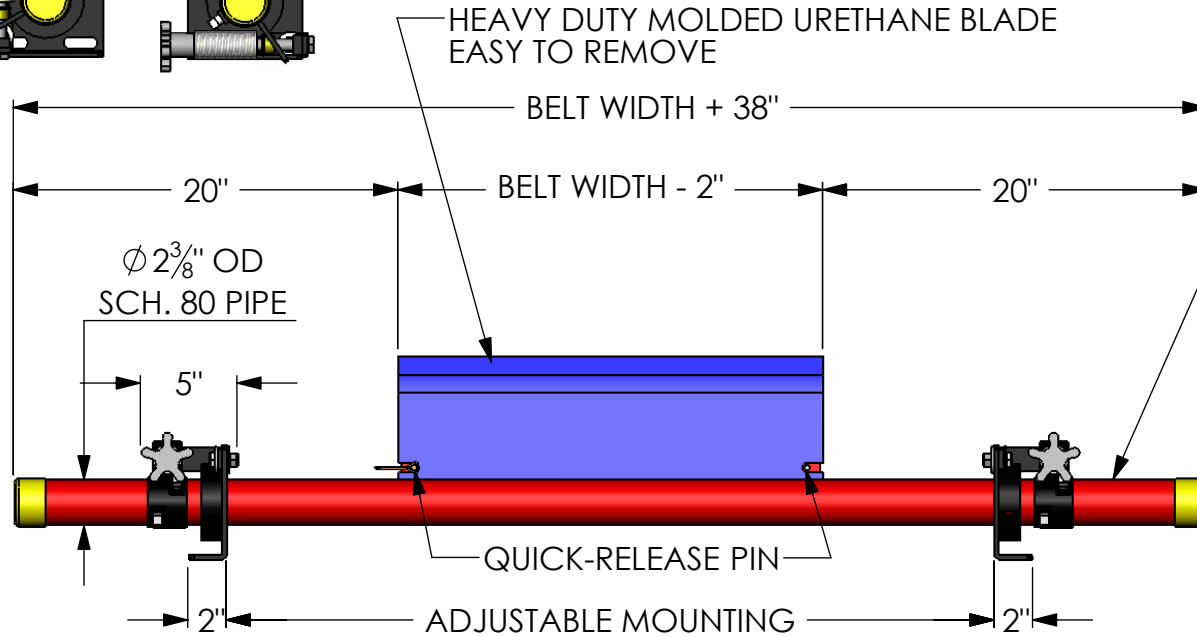

NOTE: EXCESS PIPE MAY BE CUT-OFF AFTER INSTALLATION

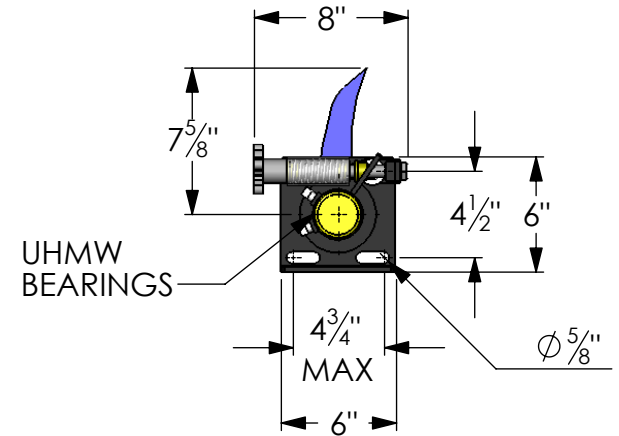

PROPRIETARY AND CONFIDENTIAL
 THE INFORMATION CONTAINED IN THIS DRAWING IS THE SOLE PROPERTY OF AMERICAN EAGLE MANUFACTURING. ANY REPRODUCTION IN PART OR AS A WHOLE WITHOUT THE WRITTEN PERMISSION OF AMERICAN EAGLE MANUFACTURING IS PROHIBITED.

		DIMENSIONS ARE IN INCHES		NAME	DATE
		TOLERANCES:		JWB	11/05/08
		FRACTIONAL ±1/16"		CHECKED	
		ANGULAR: MACH ±5° BEND ±1°		ENG APPR.	
		TWO PLACE DECIMAL ±0.05"		MFG APPR.	
		THREE PLACE DECIMAL ±0.030"		Q.A.	
		MATERIAL		COMMENTS:	
		FINISH			
NEXT ASSY	USED ON				
APPLICATION		DO NOT SCALE DRAWING			

American Eagle Manufacturing		
TITLE: MINE-DUTY PRIMARY BELT CLEANER - WITH DUAL TENSIONER 42" - 96"		
SIZE A	DWG. NO.	REV.
SCALE:1:10	WEIGHT:	SHEET 1 OF 1