

# TENSIONER MOUNTING POSITIONS

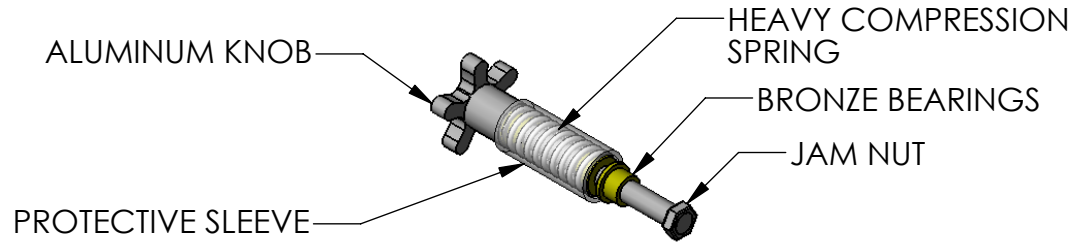

## TENSIONER DETAIL

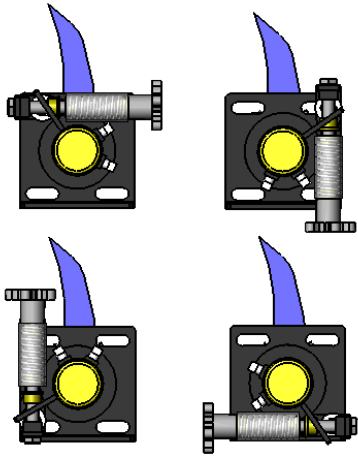
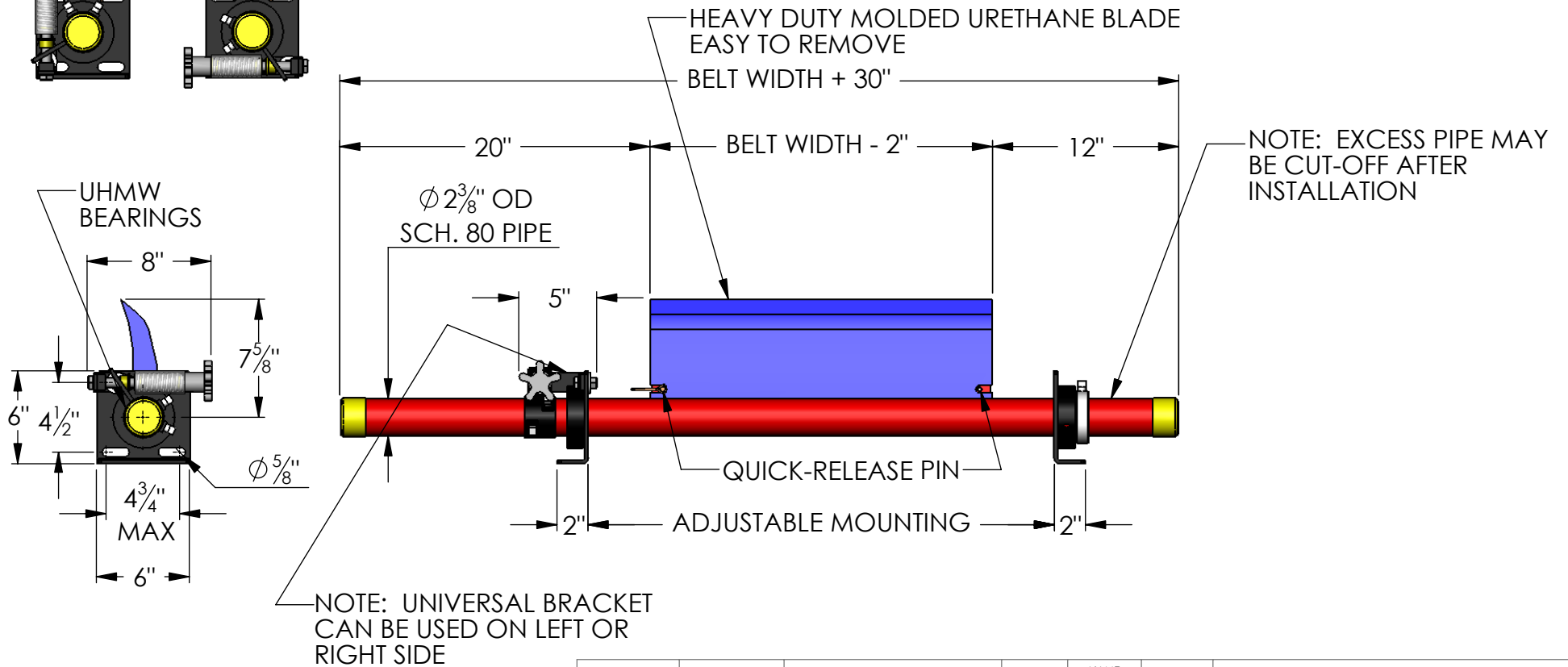

**PROPRIETARY AND CONFIDENTIAL**  
 THE INFORMATION CONTAINED IN THIS DRAWING IS THE SOLE PROPERTY OF AMERICAN EAGLE MANUFACTURING. ANY REPRODUCTION IN PART OR AS A WHOLE WITHOUT THE WRITTEN PERMISSION OF AMERICAN EAGLE MANUFACTURING IS PROHIBITED.

		DIMENSIONS ARE IN INCHES TOLERANCES: FRACTIONAL $\pm 1/16"$ ANGULAR: MACH $\pm 5^\circ$ BEND $\pm 1^\circ$ TWO PLACE DECIMAL $\pm 0.05"$ THREE PLACE DECIMAL $\pm 0.030"$		NAME JWB	DATE 11/05/08
		MATERIAL		CHECKED	
		FINISH		ENG APPR.	
NEXT ASSY	USED ON			MFG APPR.	
APPLICATION		DO NOT SCALE DRAWING		Q.A.	
				COMMENTS:	

American Eagle Manufacturing		
TITLE: MINE-DUTY PRIMARY BELT CLEANER - WITH SINGLE TENSIONER 18" - 36"		
SIZE A	DWG. NO.	REV.
SCALE: 1:10	WEIGHT:	SHEET 1 OF 1