

TENSIONER DETAIL

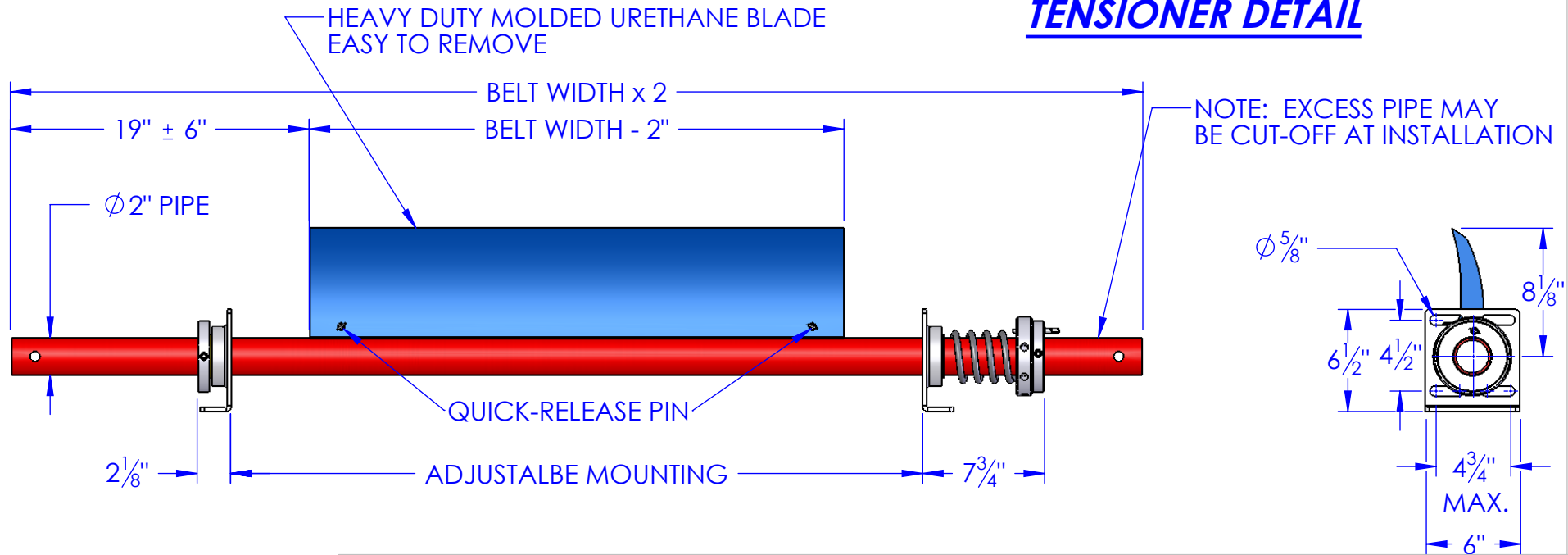

		UNLESS OTHERWISE SPECIFIED:	NAME	DATE
		DIMENSIONS ARE IN INCHES	DRAWN	WAB
		TOLERANCES:	CHECKED	02/19/07
		FRACTIONAL ± 1/16"	ENG APPR.	
		ANGULAR: MACH ± .5° BEND ± 1°	MFG APPR.	
		TWO PLACE DECIMAL ± 0.05"	Q.A.	
		THREE PLACE DECIMAL ± 0.030"	COMMENTS:	
		INTERPRET GEOMETRIC TOLERANCING PER:		
		MATERIAL		
		FINISH		
NEXT ASSY	USED ON			
APPLICATION		DO NOT SCALE DRAWING		

PROPRIETARY AND CONFIDENTIAL
 THE INFORMATION CONTAINED IN THIS DRAWING IS THE SOLE PROPERTY OF AMERICAN EAGLE MANUFACTURING. ANY REPRODUCTION IN PART OR AS A WHOLE WITHOUT THE WRITTEN PERMISSION OF AMERICAN EAGLE MANUFACTURING IS PROHIBITED.

American Eagle Manufacturing		
TITLE: HEAVY DUTY PRIMARY BELT CLEANER - WITH SINGLE TENSIONER		
SIZE	DWG. NO.	REV
A	AEP-T-BW	
SCALE: 1:10	WEIGHT:	SHEET 1 OF 1