

# OMEGA SEAL & CLAMP WORKSHEET



THIS WORKSHEET WILL HELP US TO MANUFACTURE YOUR NEW TAIL AND OMEGA SEAL TO PERFECTLY FIT YOUR CONVEYOR. PLEASE FILL OUT THESE 5 ITEMS.

## QUESTIONS?

- 1 BELT WIDTH \_\_\_\_\_
- 2 TROUGHING ANGLE  20°  35°  45°
- 3 DIMENSION **3** \_\_\_\_\_
- 4 DIMENSION **4** \_\_\_\_\_
- 5 DIMENSION **5** \_\_\_\_\_

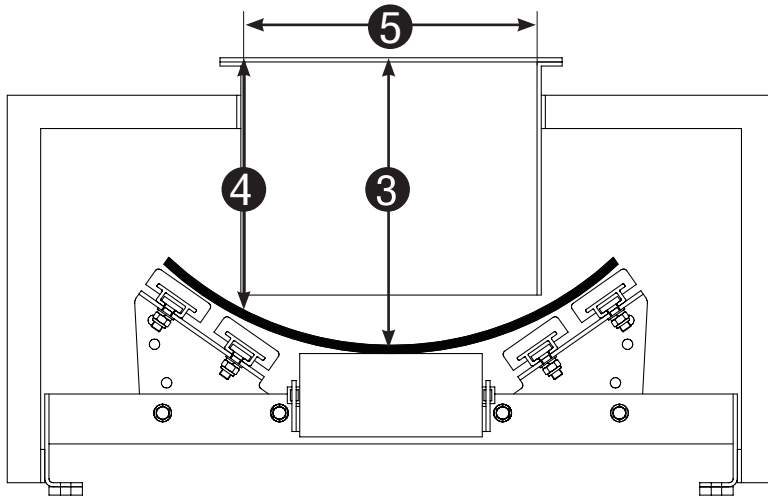

PATENT PENDING

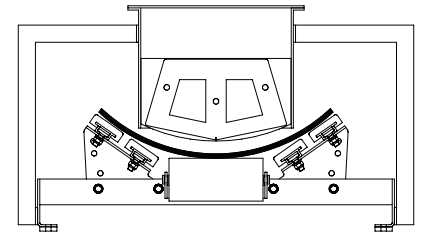
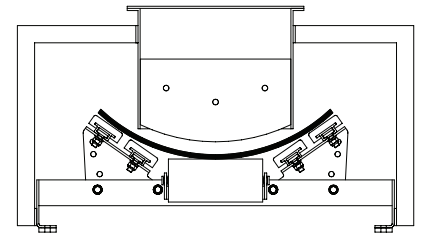
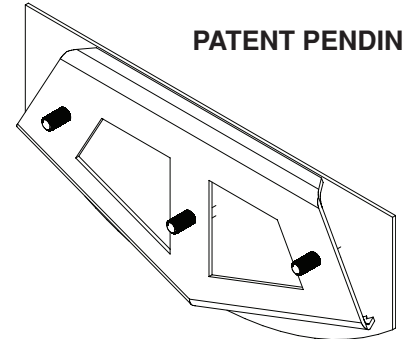

### CONTACT INFORMATION

DISTRIBUTOR \_\_\_\_\_  
 ADDRESS \_\_\_\_\_  
 \_\_\_\_\_  
 PHONE \_\_\_\_\_  
 EMAIL \_\_\_\_\_  
 CONTACT \_\_\_\_\_  
 END-USER \_\_\_\_\_  
 LOCATION \_\_\_\_\_  
 \_\_\_\_\_  
 CONVEYOR NUMBER \_\_\_\_\_

PLEASE SEND TO THE FOLLOWING:  
 Email: [sales@eagleedgeusa.com](mailto:sales@eagleedgeusa.com)  
 or Fax: (252) 633-5487

American Eagle Manufacturing LLC  
 1 866 713 8985  
 252 633 0603  
 1211 Aviation Drive  
 New Bern, North Carolina 28562  
[AmericanEagleManufacturing.com](http://AmericanEagleManufacturing.com)