

CLEANER SPECIFICATIONS				BLADE SELECTION CHART			
Part No.	Blade Width "A"	Belt Width "B"	Pipe Width "C"	MATL.	P/N SUFFIX	COLOR	DUROMETER
E5SDCSx24	22"	24"	64"	Ev-R-Wear	M	Blue	85A
E5SDCSx30	28"	30"	70"	Standard	U	Orange	85A
E5SDCSx36	34"	36"	76"	Chemical	C	Green	80A
E5SDCSx42	40"	42"	82"	High Heat	H	Red	95A
E5SDCSx48	46"	48"	88"	Food Grade	W	White	85A
E5SDCSx54	52"	54"	94"				
E5SDCSx60	58"	60"	100"				
E5SDCSx72	70"	72"	112"				

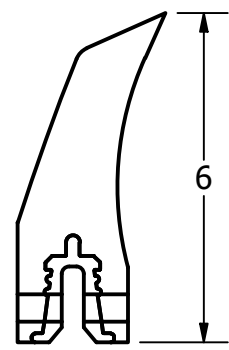

E5x Blade Profile
See BLADE SELECTION CHART for blade characteristics

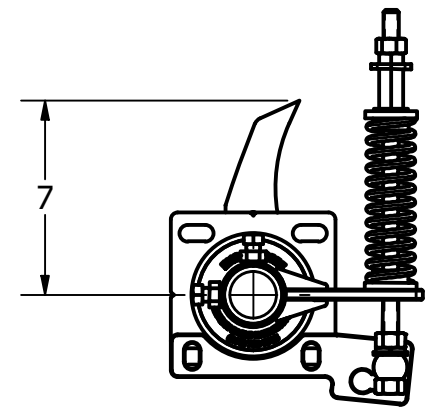
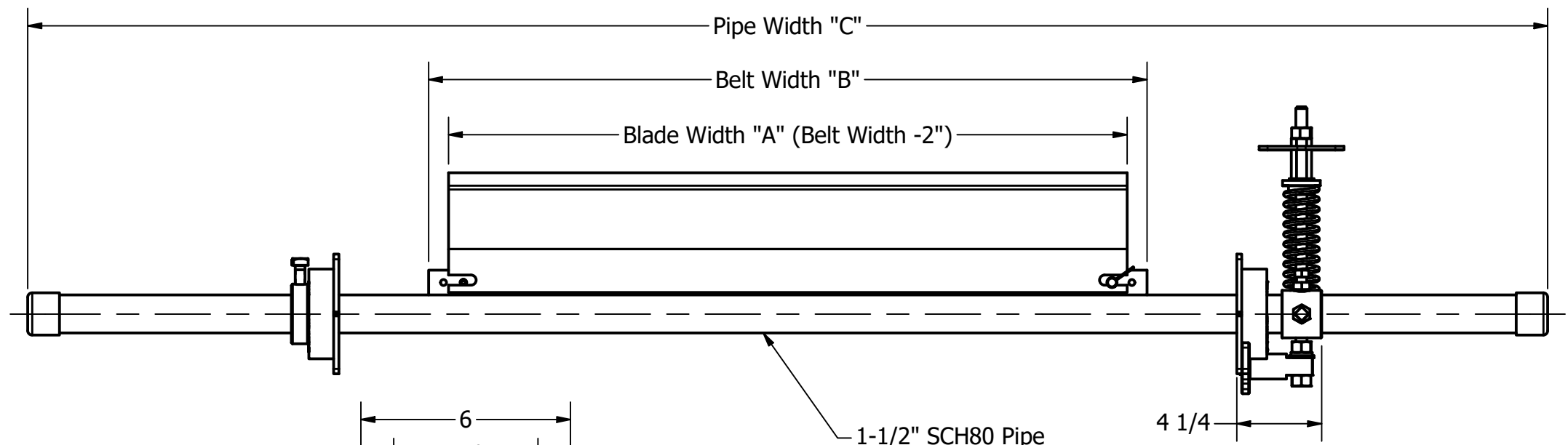
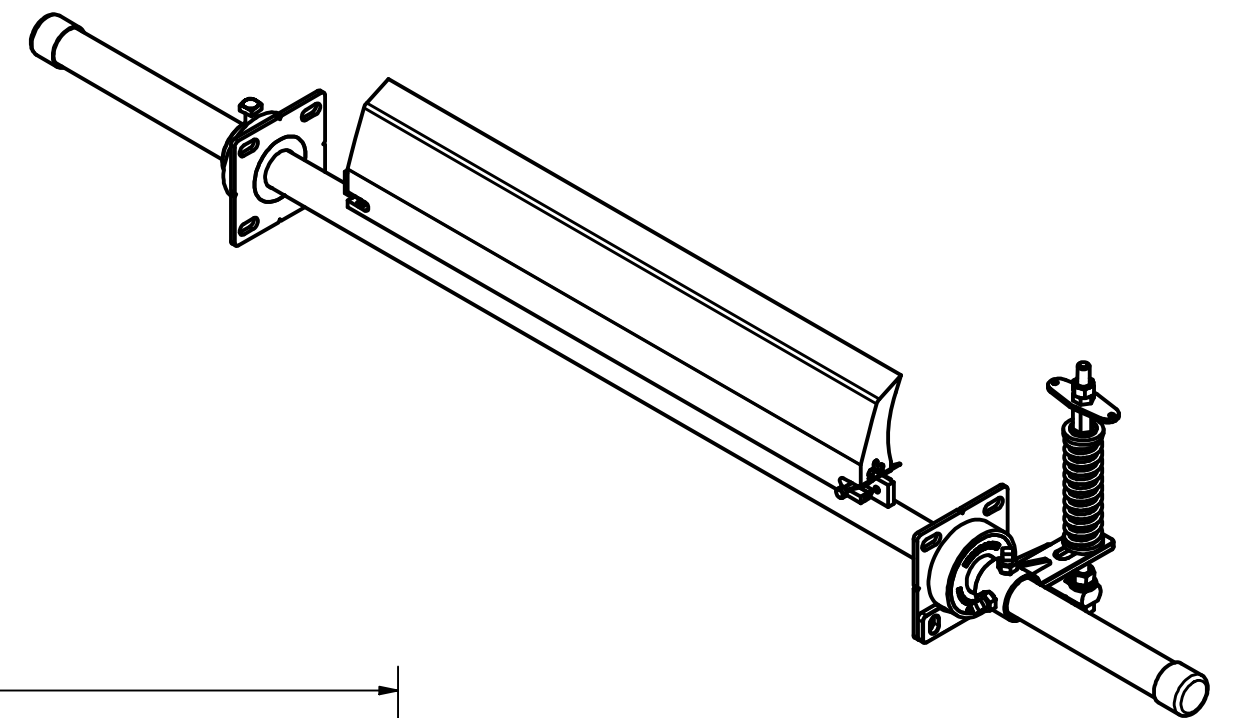
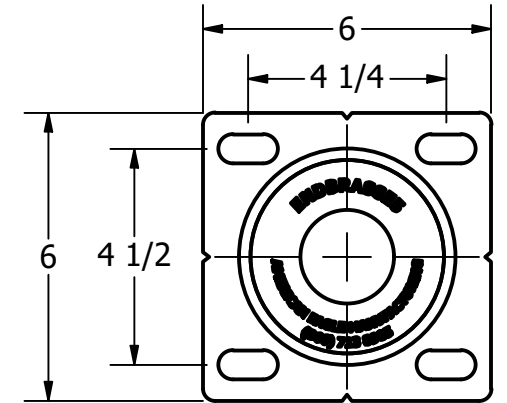

Mounting Bracket Dimensions

This drawing in design and detail is the property of American Eagle Manufacturing, LLC. It is returnable upon request and must not be reproduced or the information contained transmitted to any unauthorized person or organization without written consent from American Eagle Manufacturing, LLC. It is to be used only in connection with our work as authorized by us. All rights of design and invention are reserved.



American Eagle Manufacturing, LLC
3280 U.S. Highway 70 East
New Bern, NC 28560
Ph: 252-633-0603
Fax: 252-633-5487
www.americaneaglemanufacturing.com

TITLE E5 Standard Duty Single Tensioner Primary Cleaner			
SIZE B	DWG NO E5SDCSxENG	REV	
SCALE 1 / 7	SHEET 1 OF 1		

DRAWN JLangley	10/3/2024
APPROVED	