

IT'S THE YEAR OF
INNOVATION
AT AMERICAN EAGLE
MANUFACTURING

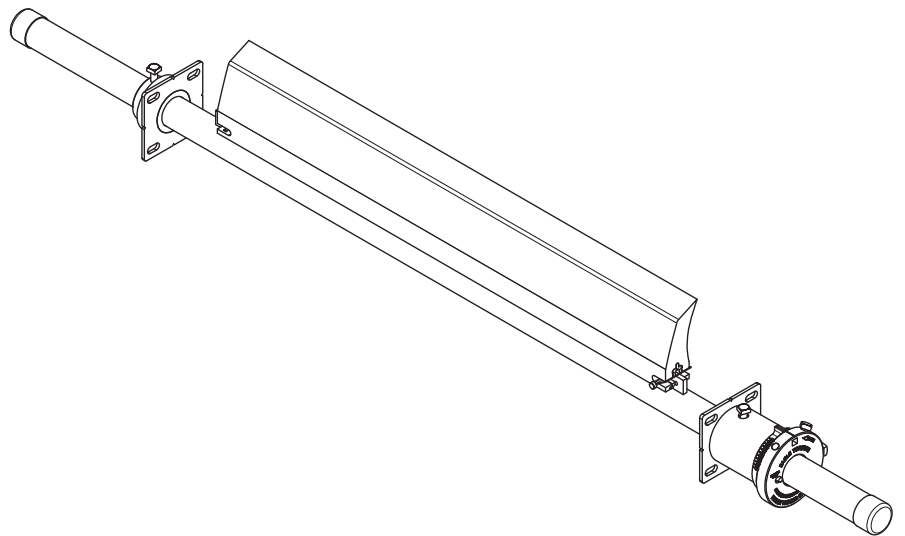

ECT5HP

INSTRUCTION MANUAL

FACILITY NAME

CONVEYOR NUMBER

DATE OF INSTALLATION

INSTALLED BY

TABLE OF CONTENTS

Disclaimer/Safety	page 3
3.1 Disclaimer	
3.2 Safety	
Installation Check List	page 4
4.1 Confirmation of Cleaner Series and Size	
4.2 Chute Installation	
4.3 Non Chute Installation	
4.4 Tools Required	
Blade Location / Material Path	page 5
Primary Cleaner Accessories	page 6
6.1 Eagle Safety Inspection Access Door	
6.2 Eagle Blade Access Plate	
6.3 Universal Telescoping Mount	
6.4 Eagle Mounting Plate	
Replacement Parts List	page 7/8
7 Single Tensioner	
8 Dual Tensioner	
Primary Cleaner Installation	page 9/15
Maintenance / Troubleshooting	page 16
12.1 Maintenance	
12.2 Troubleshooting	

DISCLAIMER/SAFETY

3.1 Disclaimer

American Eagle Manufacturing LLC disclaims any liability for improper use or application of this product not in compliance with instructions and specifications contained herein or for any damages due to contamination of material as a result of users' failure to maintain and inspect equipment. Liability shall be limited to the repair or replacement of AEM Equipment shown to be defective by cause of manufacturing.

3.2 Safety

Adhere to all safety rules defined by government (OSHA/MSHA) 1910.147, owner/employer and site specific safety rules.

- DANGER -

Lockout/Tagout procedures must be followed before any maintenance, service, repair, or installation of equipment begins on the conveyor. Failure to follow all safety rules can result in injury or death.



INSTALLATION CHECK LIST

4.1 Confirmation of Cleaner Series and Size

- A) Match recommended cleaner to pulley diameter
- B) Confirm blade tip location. (see page 5)
- C) Confirm blade width to material path (see page 5)

4.2 Chute installation

- A) Choose location of tensioner (on left or right side of chute wall). Make this decision based on ease of maintenance of tensioner and blade replacement.
- B) Pre-check any obstructions for proper location
- C) Confirm adequate access to inside of chute. Chute should have access door or access panel for blade replacement and maintenance. (see page 6 for Eagle Safety Inspection Access Door and/or Eagle Blade Access Plate, if necessary)
- D) Confirm Standard mounting tube length is adequate (see page 7 item 2)

4.3 Non-Chute installation

- A) You will need to have a plan to install cleaner without a chute wall. This can be done by fabricating panels and welding to both sides of conveyor frame. We also offer two pre-manufactured solutions to this problem. (see page 6 for the Universal Telescoping Mount or the Eagle Mounting Plate, if necessary)
- B) Pre-check any obstructions for proper location

4.4 Tools Required

Personal safety equipment as required by OSHA/MSHA and site specific guidelines.

Standard hand tools, cutting torch, welder, grinder, soap stone or marker and fire protection.

BLADE LOCATION

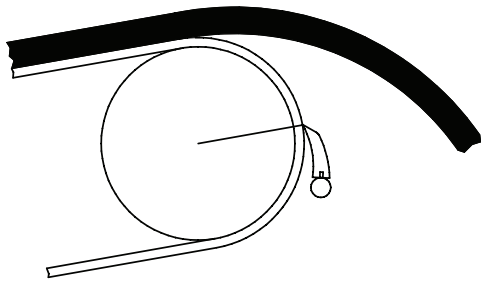

Selecting the blade-tip location is the first critical decision that will contribute to maintaining the life of your blade.

The blade should never be used as a ramp for material to slide over. The bulk of the material should gravity-fall over the face of the blade. Blade wear should occur at blade-tip, at point of contact with the belt, not the face of the blade.

**AVERAGE SPEED
NORMALLY 300-350FPM**

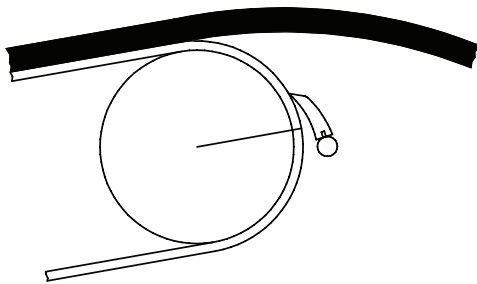

**BELT SPEEDS NORMALLY
400FPM**

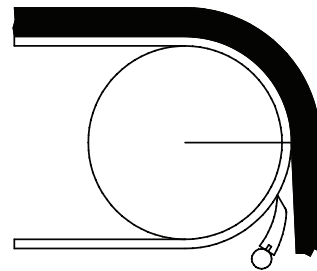

**SLOW MOVING BELT SPEED
NORMALLY 100FPM**

MATERIAL PATH

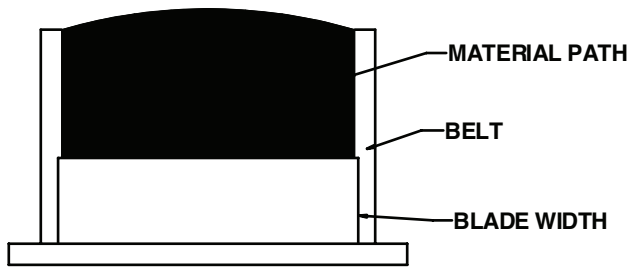

CORRECT

The second critical determination for blade life is the blade width itself, which will also influence the cleanliness of your belt. You will need a blade width of -2 (standard) or -8, depending on the center path of the material as it travels the belt.

75% of all premature blade-failure is the result of improper blade width.

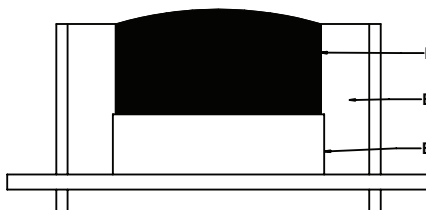

**CORRECT BLADE
WIDTH RESULTS
IN EVEN WEAR**

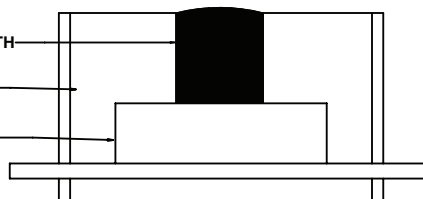

**BLADE DOESN'T
MATCH MATERIAL
PATH...**

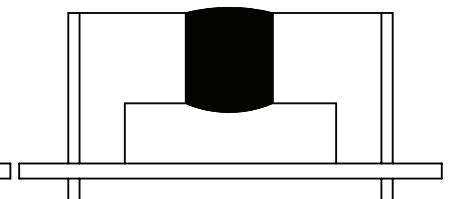

**...RESULTING
IN POOR BLADE
WEAR**

PRIMARY CLEANER ACCESSORIES

Eagle Safety Inspection Access Door

Eagle Safety Inspection Access Door is designed for chute inspection and easier maintenance of primary cleaners, including blade change-out. Constructed of all steel, the doors are laser cut, formed and powder coated for a trouble free life.

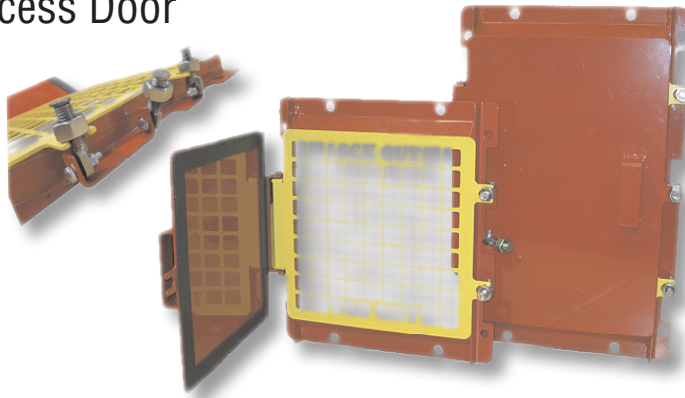

Part Number	Size
ESIAD9x12	9"x12"
ESIAD12x12	12"x12"
ESIAD12x18	12"x18"
ESIAD18x18	18"x18"
ESIAD18x24	18"x24"
ESIAD24x24	24"x24"
ESIAD24x48	24"x48"
ESIAD42x42	42"x42"

Eagle Blade Access Plate

Designed to eliminate a major safety hazard, Eagle Blade Access Plate allows removal of the entire primary cleaner as a cartridge from one side of the headbox. This eliminates personnel having to get inside of the headbox, creating a safer work environment. By simply removing six bolts on one side and the set collar on the other, two people can change-out the blade and return the cleaner to its operating position quickly and safely.



Part Number	Size
EBAP-1	17"x11-1/2"

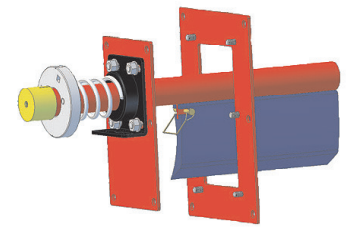

Universal Telescoping Mount

This low cost mount provides quick installation of primary cleaners, lightening the burden of future maintenance. With our universal cleaner mounting bracket you can mount underneath, on the outside, or inside of the telescoping bracket. No one else offers these options!

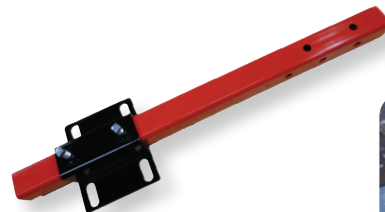

Part Number	Size
UTM30	30"
UTM48	48"

(set of 2)



Eagle Chute Mounting Plates

These plates will help close up any existing holes of other cleaners that were not properly installed.



Part Number	Size
ECMP-0810	8"x10"

(set of 2)

ECT5HP SINGLE TENSIONER REPLACEMENT PARTS

Parts List			
Num.	Part Number	Description	Qty.
①	E5xxx	Blade	1
②	E5PBxx	Mounting Pipe	1
③	ECT1001	Covered Tension Bracket-E5 Cleaner	1
④	E1-010	RH Torsion Spring (Silver Spring)	1
⑤	E1-009	LH Torsion Spring (Black Spring)	1
⑥	ENDBRASS-E5	E5 Series Mounting Bracket	1
⑦	ECT1005	Tension Indicator	1
⑧	COLLAR012-BR	Eagle Torsion Collar-E5 Cleaner	1
⑨	COLLAR003	Shaft Collar	1
⑩	9753K77	Pipe End Caps	2
⑪	BLADEPINKIT	Blade Pins	1
⑫	TORSIONROD	Torsion Rod	1
⑬	W3213685	Hardware Kit	1

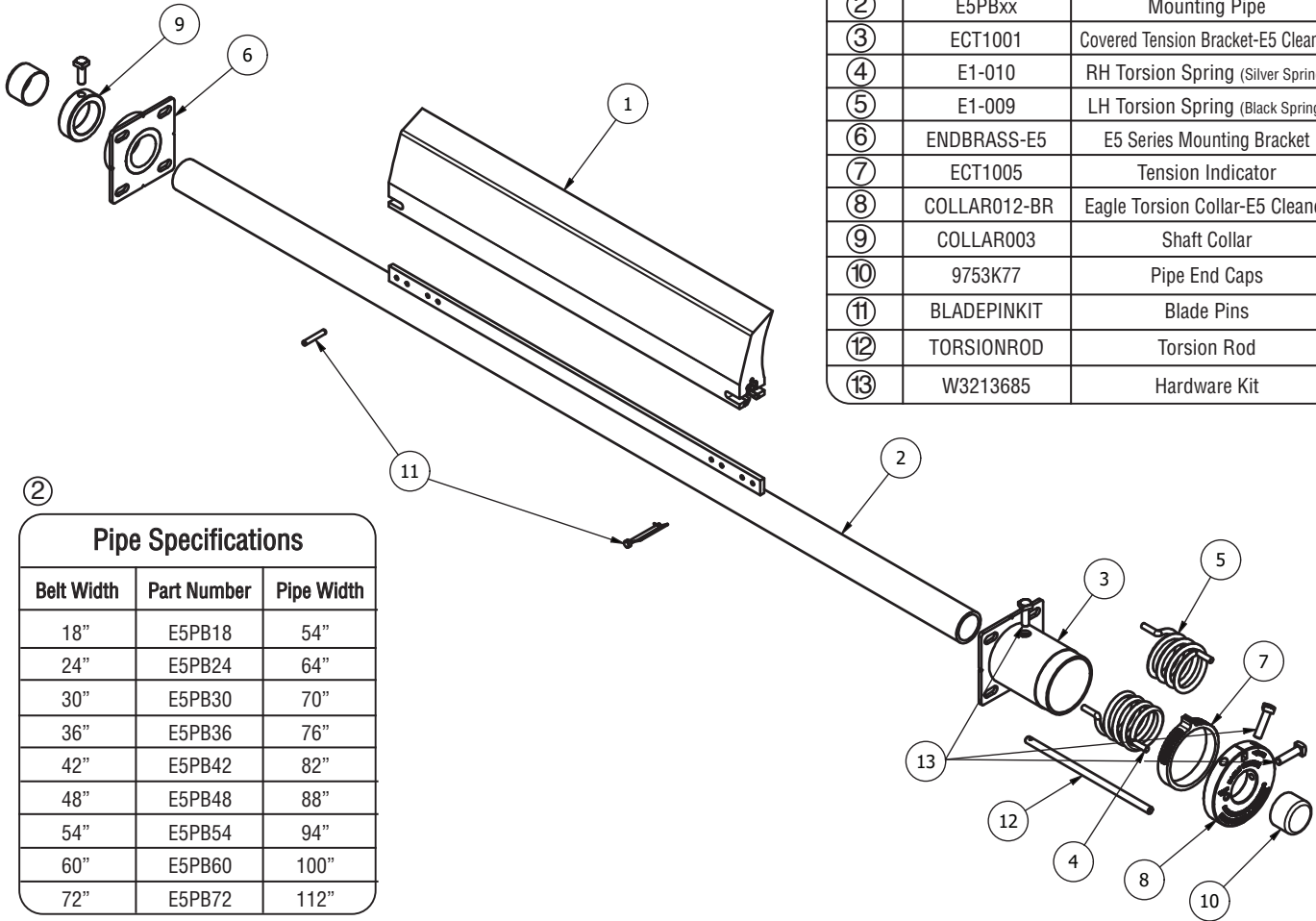

Pipe Specifications		
Belt Width	Part Number	Pipe Width
18"	E5PB18	54"
24"	E5PB24	64"
30"	E5PB30	70"
36"	E5PB36	76"
42"	E5PB42	82"
48"	E5PB48	88"
54"	E5PB54	94"
60"	E5PB60	100"
72"	E5PB72	112"

Blade Specifications											
Belt Width	Blue Ev-R-Wear High Performance		Orange Standard Economy Blade		Green Chemical Resistant		Red High Heat (Max. 275°F)		White FDA Compliant		
	-2" Belt Width	-8" Belt Width	-2" Belt Width	-8" Belt Width	-2" Belt Width	-8" Belt Width	-2" Belt Width	-8" Belt Width	-2" Belt Width	-8" Belt Width	
18"	E5M16	E5M10	E5U16	E5U10	E5C16	E5C10	E5H16	E5H10	E5W16	E5W10	
24"	E5M22	E5M16	E5U22	E5U16	E5C22	E5C16	E5H22	E5H16	E5W22	E5W16	
30"	E5M28	E5M22	E5U28	E5U22	E5C28	E5C22	E5H28	E5H22	E5W28	E5W22	
36"	E5M34	E5M28	E5U34	E5U28	E5C34	E5C28	E5H34	E5H28	E5W34	E5W28	
42"	E5M40	E5M34	E5U40	E5U34	E5C40	E5C34	E5H40	E5H34	E5W40	E5W34	
48"	E5M46	E5M40	E5U46	E5U40	E5C46	E5C40	E5H46	E5H40	E5W46	E5W40	
54"	E5M52	E5M46	E5U52	E5U46	E5C52	E5C46	E5H52	E5H46	E5W52	E5W46	
60"	E5M58	E5M52	E5U58	E5U52	E5C58	E5C52	E5H58	E5H52	E5W58	E5W52	
72"	E5M70	E5M64	E5U70	E5U64	E5C70	E5C64	E5H70	E5H64	E5W70	E5W64	

ECT5HP DUAL TENSIONER REPLACEMENT PARTS

Parts List

Num.	Part Number	Description	Qty.
①	E5xxx	Blade	1
②	E5PBxx	Mounting Pipe	1
③	ECT1001	Covered Tension Bracket-E5 Cleaner	2
④	E1-010	RH Torsion Spring (Silver Spring)	1
⑤	E1-009	LH Torsion Spring (Black Spring)	1
⑥	ECT1005	Tension Indicator	2
⑦	COLLAR012-BR	Eagle Torsion Collar-E5 Cleaner	2
⑧	9753K87	Pipe End Caps	2
⑨	TORSIONROD	Torsion Rod	2
⑩	W3213685	Hardware Kit	2
⑪	BLADEPINKIT	Blade Pins	1

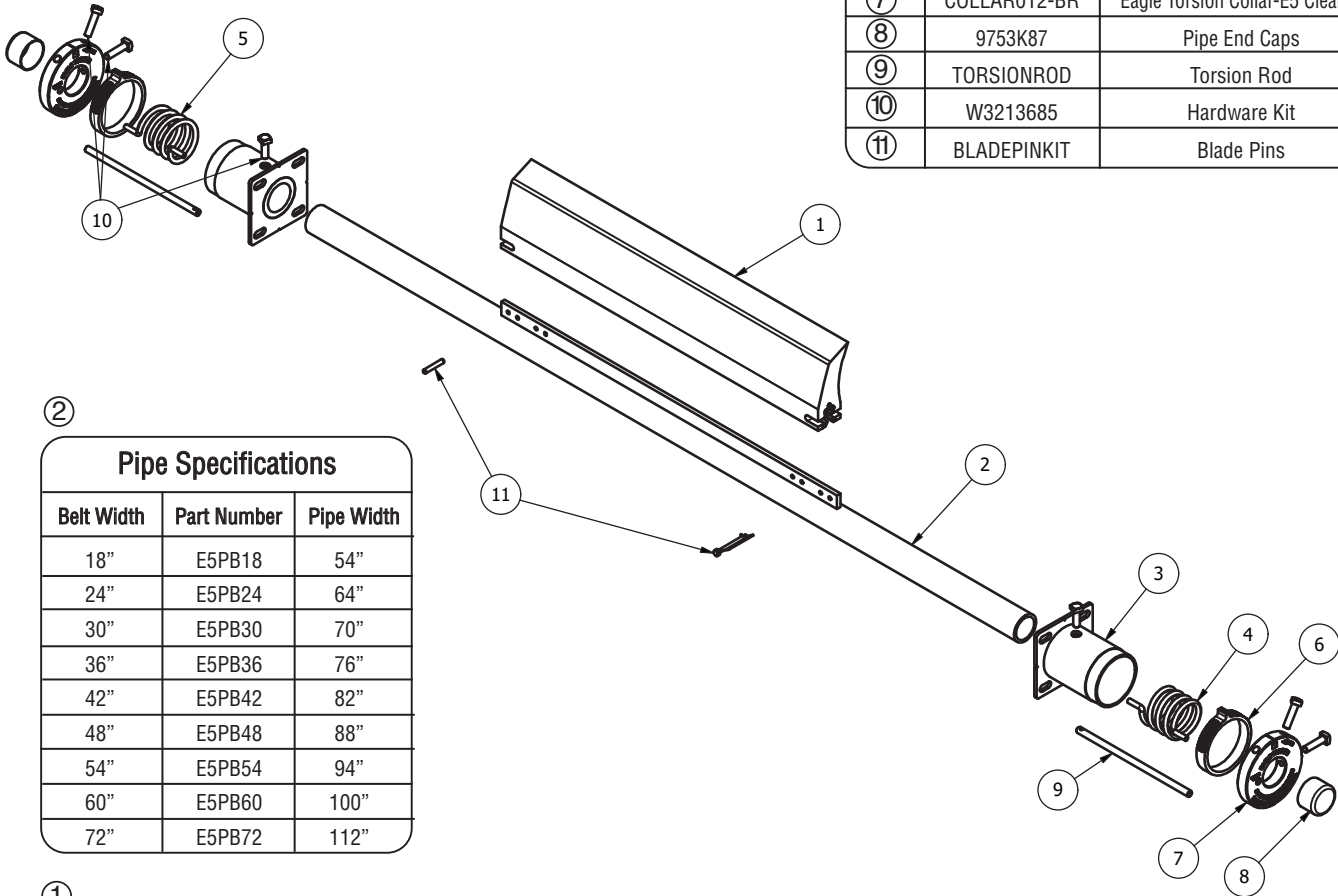

Pipe Specifications

Belt Width	Part Number	Pipe Width
18"	E5PB18	54"
24"	E5PB24	64"
30"	E5PB30	70"
36"	E5PB36	76"
42"	E5PB42	82"
48"	E5PB48	88"
54"	E5PB54	94"
60"	E5PB60	100"
72"	E5PB72	112"

Blade Specifications

Belt Width	Blue Ev-R-Wear High Performance		Orange Standard Economy Blade		Green Chemical Resistant		Red High Heat (Max. 275°F)		White FDA Compliant	
	-2" Belt Width	-8" Belt Width	-2" Belt Width	-8" Belt Width	-2" Belt Width	-8" Belt Width	-2" Belt Width	-8" Belt Width	-2" Belt Width	-8" Belt Width
18"	E5M16	E5M10	E5U16	E5U10	E5C16	E5C10	E5H16	E5H10	E5W16	E5W10
24"	E5M22	E5M16	E5U22	E5U16	E5C22	E5C16	E5H22	E5H16	E5W22	E5W16
30"	E5M28	E5M22	E5U28	E5U22	E5C28	E5C22	E5H28	E5H22	E5W28	E5W22
36"	E5M34	E5M28	E5U34	E5U28	E5C34	E5C28	E5H34	E5H28	E5W34	E5W28
42"	E5M40	E5M34	E5U40	E5U34	E5C40	E5C34	E5H40	E5H34	E5W40	E5W34
48"	E5M46	E5M40	E5U46	E5U40	E5C46	E5C40	E5H46	E5H40	E5W46	E5W40
54"	E5M52	E5M46	E5U52	E5U46	E5C52	E5C46	E5H52	E5H46	E5W52	E5W46
60"	E5M58	E5M52	E5U58	E5U52	E5C58	E5C52	E5H58	E5H52	E5W58	E5W52
72"	E5M70	E5M64	E5U70	E5U64	E5C70	E5C64	E5H70	E5H64	E5W70	E5W64

ECT5HP INSTALLATION INSTRUCTIONS

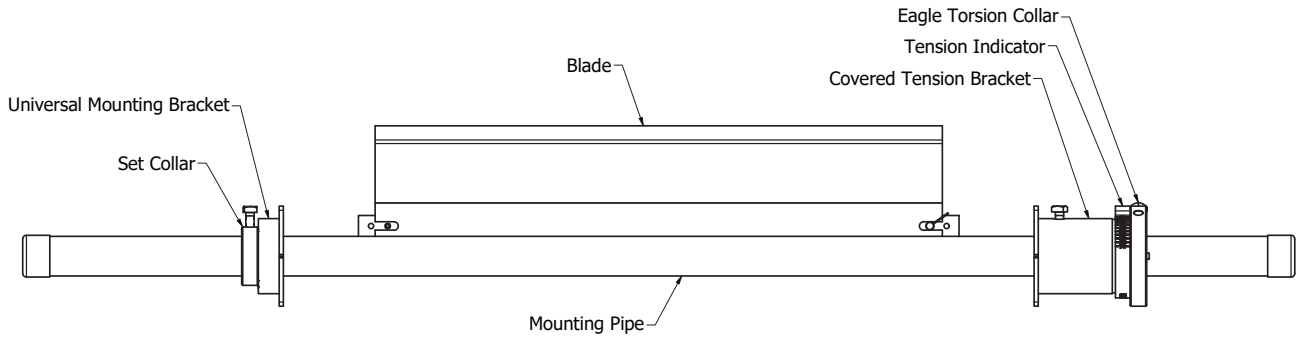

Single Tensioner Assembly

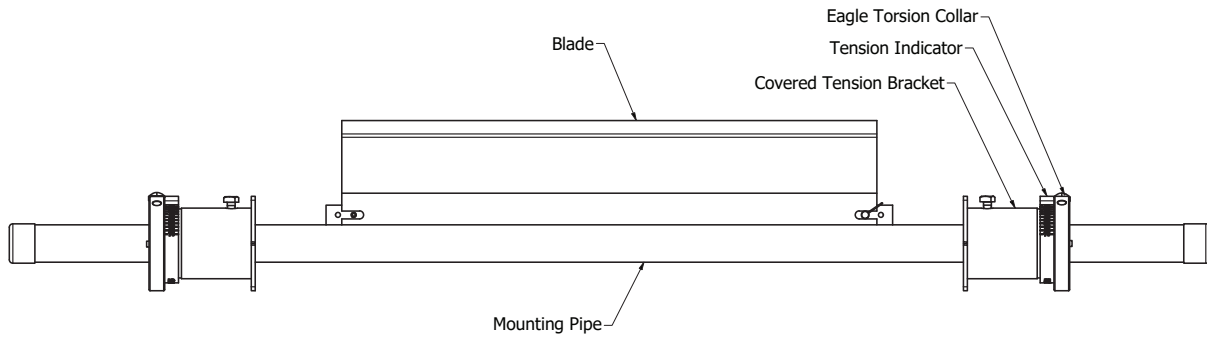

Dual Tensioner Assembly

***IMPORTANT:** MAKE SURE CONVEYOR IS LOCKED OUT/TAGGED OUT BEFORE ANY WORK BEGINS.

Step 1.

Inspect the conveyor head pulley. If there is a chute surrounding the head pulley continue to Step 2. A conveyor without a chute will require either mounting plates or a universal mounting bracket. ***SEE PAGE 6 FOR OPTIONS**

Conveyor
With Chute

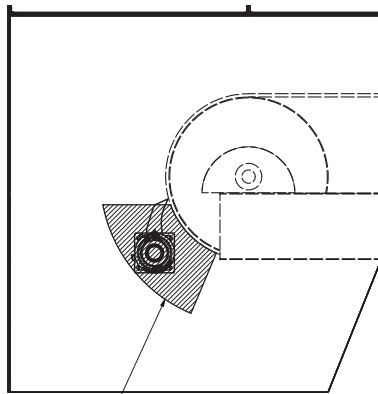

Keep area clear of all obstructions
(i.e. hoses, lines, electrical wire)
and any other mounted components

Conveyor
without Chute

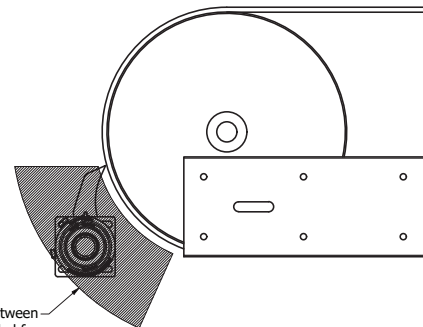

You will need to bridge the gap between
conveyor and proper location needed for
belt cleaner installation
***SEE PAGE 6 FOR OPTIONS**

ECT5HP INSTALLATION INSTRUCTIONS

Step 2.

Determine pulley diameter, measuring from the center of the shaft to pulley surface "A" dimension. Multiply "A" dimension x2 for pulley diameter. Using the Gap Chart and pulley diameter, determine "G" dimension. This is the distance from the center of the mounting tube to the face of the belt.

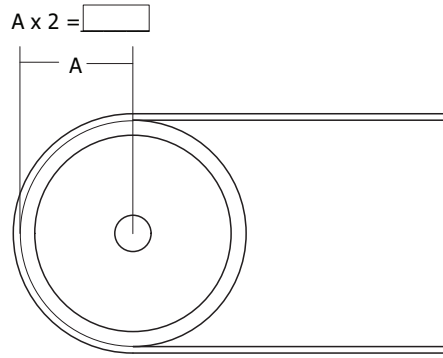

Gap Dimension Chart	
PULLEY DIAMETER	GAP
8" - 16"	4"
18" - 30"	3-1/2"
36" +	2-3/4"
TOLERANCES + OR - 1/4"	

Your Gap Dimension

Step 3.

After determining the Gap "G" dimension transfer G + A dimensions to the chute wall in an arc from 7 o'clock to 9 o'clock. If working from inside the chute transfer "G" dimension from 7 o'clock to 9 o'clock on the chute wall.

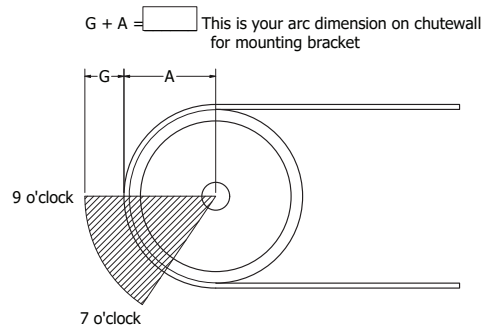

Step 4.

Determine blade-tip contact point, usually between 9 o'clock and 7 o'clock.

NEVER PLACE THE BLADE IN THE MATERIAL PATH

After establishing the blade tip contact point, measure 7" and mark with soap stone or marker crossing an intersecting arc with the "G" dimension arc on the chute wall. This will be the center of the mounting pipe.

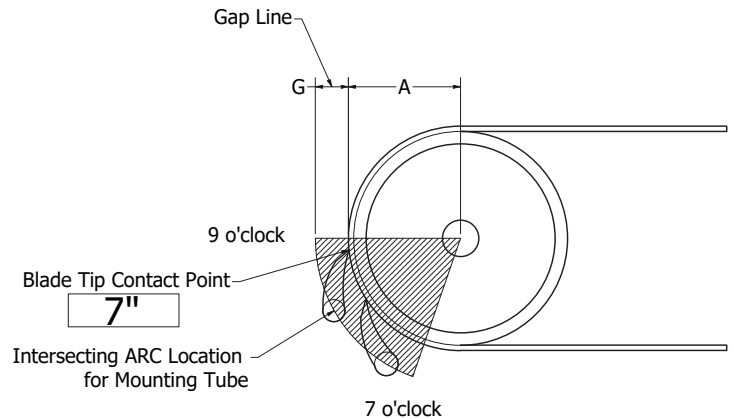

ECT5HP INSTALLATION INSTRUCTIONS

Step 5.

Center mounting bracket over the intersecting arc dimensions on the chute wall with bolt slots vertical. Trace the bracket plate center and slots with soap stone or marker. Cut the center hole 3 1/2" and bolt holes as marked. This allows adjustment of the mounting pipe.

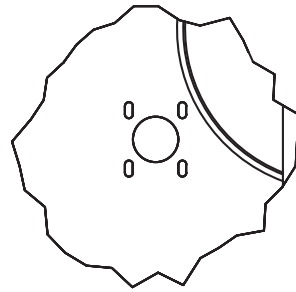

DETAIL A
SCALE 1 / 8

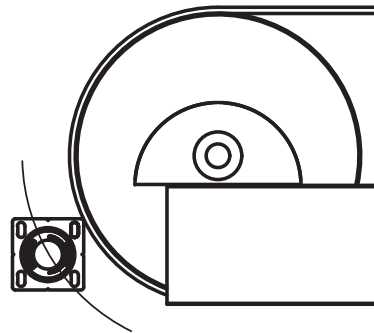
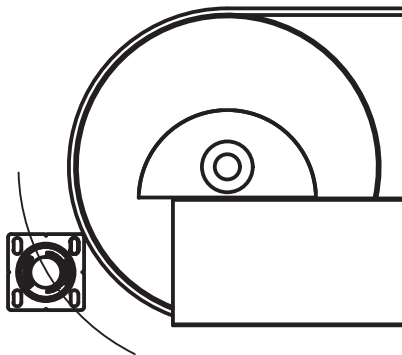

Step 6.

Pass the mounting pipe through the access holes and install the mounting brackets to the chute wall. Facing the head pulley, install the covered tension bracket to the chute wall on either the left or right side as desired.

NOTE: If installing a Dual Tensioner Assembly, install the covered tension brackets on both sides of chute.

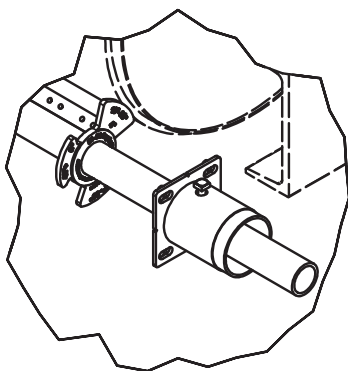

DETAIL A
SCALE 1 / 8

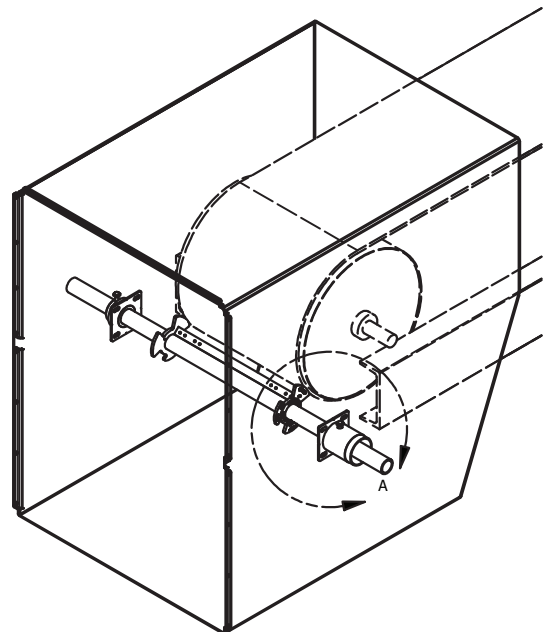

ECT5HP INSTALLATION INSTRUCTIONS

***IMPORTANT: INSTALL THE GAP INDICATORS ON THE MOUNTING PIPE BOTH LEFT AND RIGHT SIDE.**

Step 6 (Cont.)

Rotate to the correct "G" dimension marked on the gap indicator. Tighten mounting brackets finger tight. Place a level on the mounting pipe to check for level and square. Tighten all mounting bolts. Install the blade on the mounting pipe.

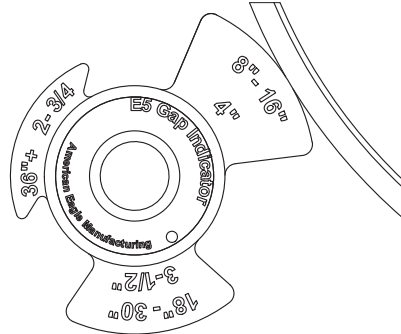

PULLEY DIAMETER	GAP
8" - 16"	4"
18" - 30"	3-1/2"
36" +	2-3/4"
TOLERANCES + OR -1/4"	

Your Gap Dimension

Step 7.

Center the blade on the head pulley. Determine which side of conveyor to install torsion spring tensioner assembly. Install the set collar on the non-tension side.

NOTE: If installing a Dual Tensioner Assembly, install the torsion spring tensioner assembly on both sides of the chute .

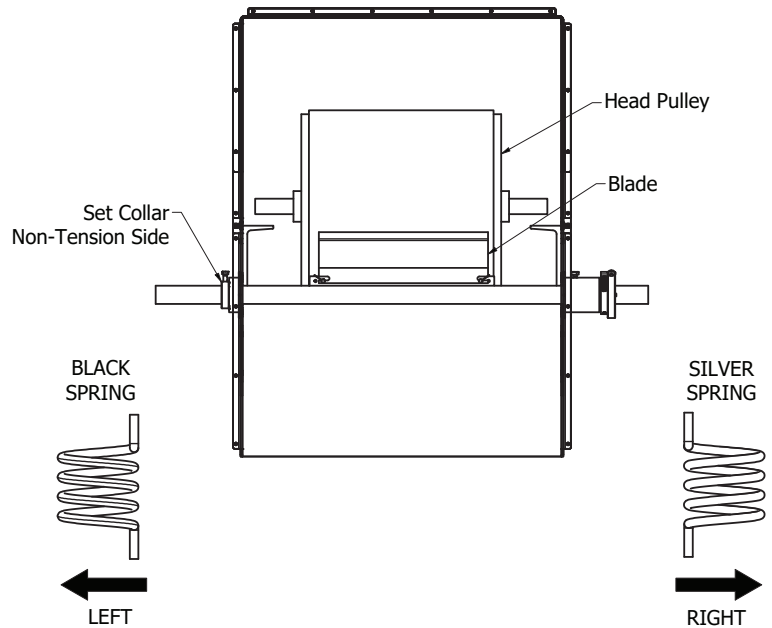

ECT5HP INSTALLATION INSTRUCTIONS

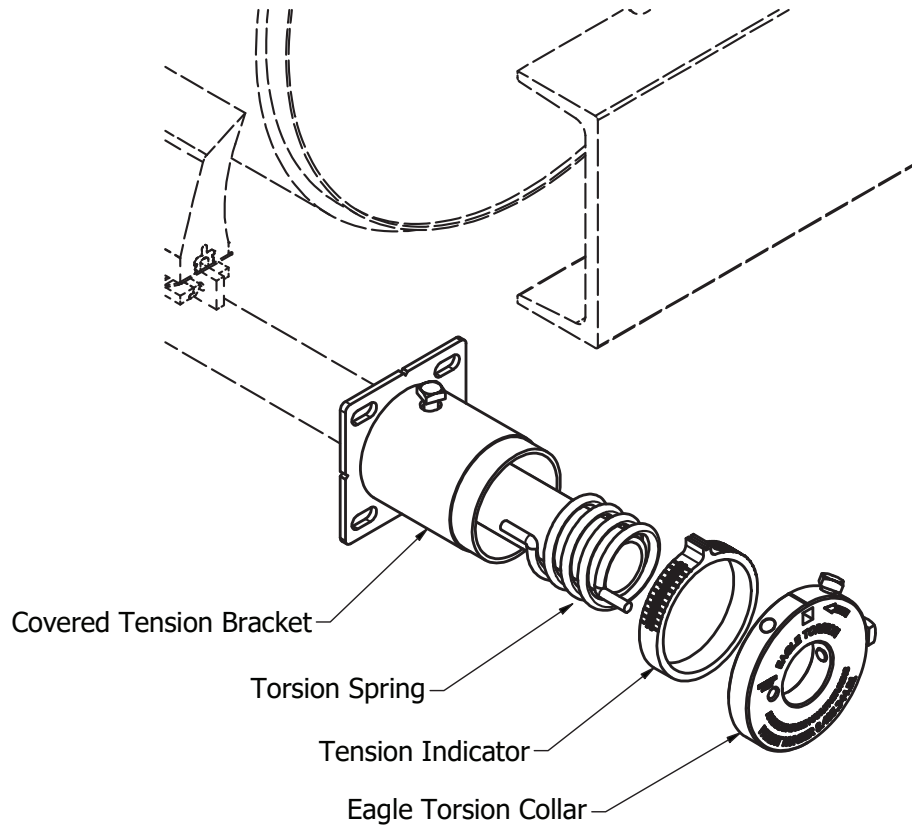

Step 8.

Rotate blade into operating position. Tighten the hold down set screw. This will hold the blade in place while setting tension.

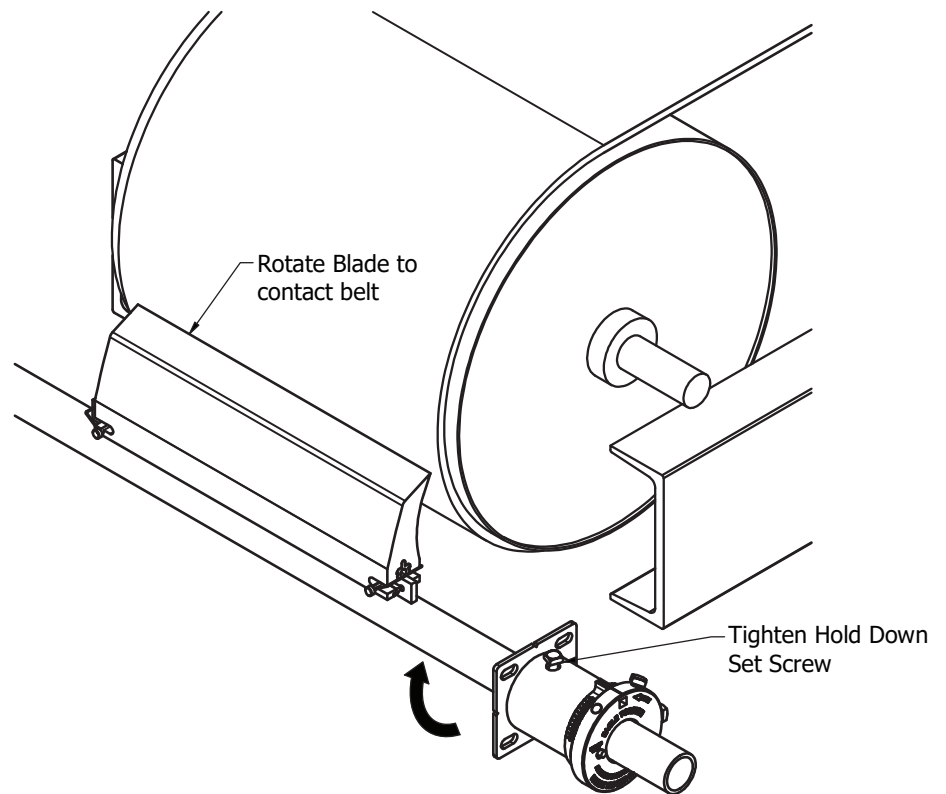

ECT5HP INSTALLATION INSTRUCTIONS

Step 9.

Align the groove on the tension indicator with the scribed line on the eagle torsion collar.

Using either the provided torsion rod in **Option 1** or a torque wrench in **Option 2**, pull back on the eagle torsion collar until the correct poundage is aligned on both the eagle torsion collar and the tension indicator.

Suggested tension is one pound per inch of blade width (see Tension Chart below). Lock down set screws on the eagle torsion collar to the mounting pipe.

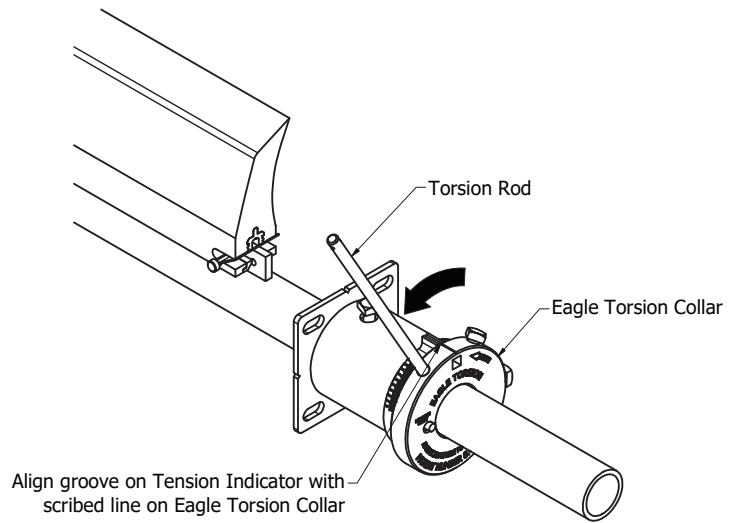

Option 1

IMPORTANT NOTICE:

*Release hold down set screw on mounting bracket **AFTER** eagle torsion collar is set*

Check the operation of the cleaner using torsion rod. Pull back and release to insure proper operation. When resetting tension on the cleaner follow Steps 8 and 9.

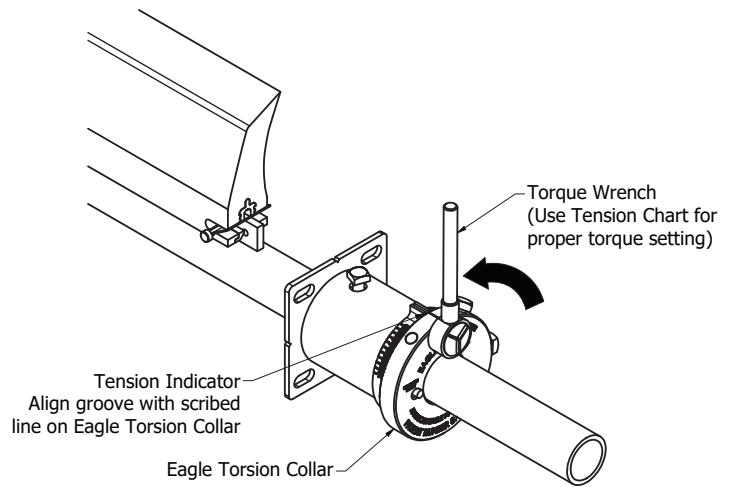

Option 2

Tension Chart		
BELT WIDTH	BLADE WIDTH	TENSION (LBS.)
18	16	16
24	22	22
30	28	28
36	34	34
42	40	40
48	46	46
54	52	52
60	58	58
72	70	70

Step 10.

Trim the mounting pipe 3" from the tension or non-tension sides and install the yellow safety caps.

NOTE: Display safety stickers on chute wall or other clearly visible area.

Step 11.

Test run the conveyor to check proper installation.

MAINTENANCE

1) INSTALLATION INSPECTION

After the cleaner has been installed and run for several days, a visual inspection should be made to ensure proper cleaning. At this time make any needed adjustments. Recheck all fasteners on mounting. Routine inspections.

2) VISUAL INSPECTIONS ON A REGULAR BASIS EVERY FOUR WEEKS

Check for cleaner performance including tension and material build up on blade. Check belt for any damage areas or splice damage.

3) BLADE WEAR INSPECTIONS

Inspect that blade wear is even across blade (if center wear appears, change to a narrower blade. Blade should be only slightly larger than material path). Always check for correct tension settings.

TROUBLESHOOTING

INSUFFICIENT CLEANING	1) Tension too low (set tension as listed in installation) 2) High blade wear (replace blade)
IRREGULAR BLADE WEAR	1) Worn in center of the blade (install narrower blade covering material path) 2) Worn unevenly (check "G" dimension, level & square) 3) Check belt splices/clips and install new blade
VIBRATION, CHATTER	1) Tension too high or too low (check and adjust tension as listed in installation instructions) 2) Blade worn changing angle (replace blade) Contact American Eagle to ensure correct blade is being used
CLEANER, BLADE FLIPPED	Blade flipped, pulled through. (Check installation "G" dimension noted on page 10) Replace blade.



American Eagle Manufacturing LLC
1 866 713 8985
252 633 0603
New Bern, North Carolina 28562
AmericanEagleManufacturing.com